

Type: \_\_\_\_\_

Model: \_\_\_\_\_

Project: \_\_\_\_\_

### MODEL: **ML45-LED** | MINI MARKER LIGHT

A discrete integrated LED fixture for fences, deck posts, wood retaining walls, and other perimeter lighting applications. Serves as a marking light for the surface it is installed into.

**CONSTRUCTION:** Polycarbonate body.

**WARRANTY:** Lifetime warranty on fixture.

**CERTIFICATIONS:** Complies with the requirements of UL-1838 and CAN/CSA-C22.2 No. 250.7. Identified with the ETL & cETL Listed Mark.

**WIRING:** Preinstalled 10' 18AWG wire

#### DIMENSIONS

Diameter: \_\_\_\_\_ 0.91 inches

Depth: \_\_\_\_\_ 1.28 inches

Ship Weight: \_\_\_\_\_ <0.5 lbs

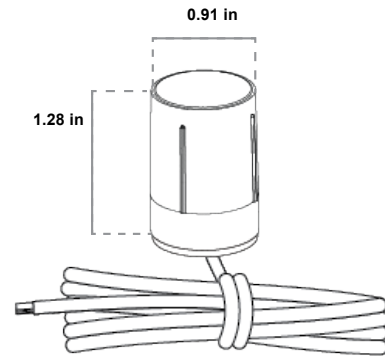

#### INTEGRATED LED MODULE DETAILS:

<b>WATTS:</b>	0.64W
<b>COLOR:</b>	Soft White
<b>COLOR TEMPERATURE:</b>	2700K
<b>LUMENS:</b>	33.8lm
<b>BEAM ANGLE:</b>	320°
<b>DIMMING:</b>	None

